

Hooklift TL20 L Modular System

- Hoisting capacity 20 t
- Hook height 1570 mm
- Interchangeable bolted hook
- Mechanical hook security
- Additional heavy-duty sliding pads fitted inside the main arm
- Sliding arm
- Front bridge cylinder connection cross-member with drilling for quick assembly
- Flow control 3 elements hydraulic
- Rear head in high tensile steel, drilled and threaded for quick assembly
- Counterhook safety system during tipping
- High-strength steel subframe with longitudinal piercing for quick assembly
- Standard track equipment width 1060 mm
- Oil Tank lateral 100 lt
- External hydraulic locking
- CE preparation
- Hidden lateral rigid piping
- Central container supports with integrated sliding rollers
- ABS mudguards
- Rear lights Rear Lights with protection grille
- Installation of perimeter panelling
- Interlock safety system
- Soft start - soft touch speed control
- Electrical system voltage 24 volt
- Pneumatic cab. control
- Fully sheated electrical system with IP65 protection
- Final single color enamel painting
- Rear underrun protection Rear underrun protection
- Light alloy cyclist protection
- Black ABS tool box
- High-visibility LED perimeter markers
- Retro-reflecting perimeter strips

Hooklift TL20

- Explorer version
- Rear foldable reinforced stabilizer
- Flow control additional element with cab control and monitoring for rear stabilizer activation
- Frontal oil Tank 110 lt

T20 MS

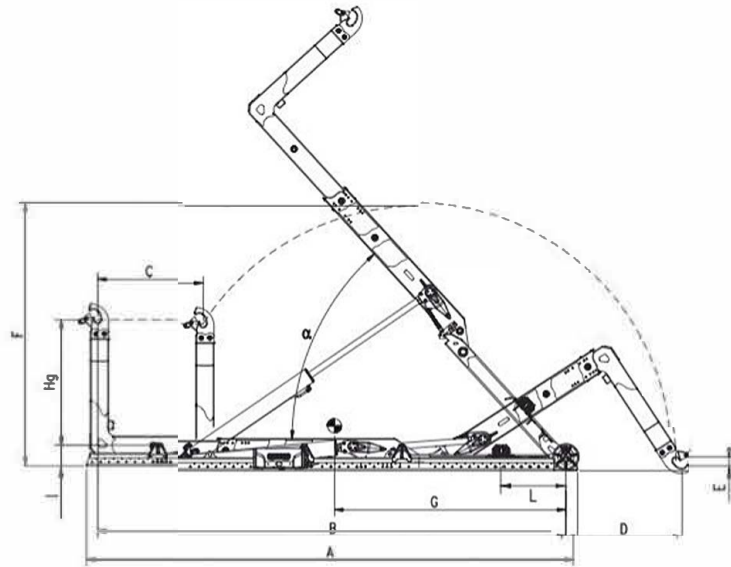

T20 MS

CONTAINER

MODEL	HG	A	B	C	D	E	F	G	I	L	WEIGHT	α	MIN	MAX
T20 XC MS	1425/1570	5280	4600	800	1740	100	3060	2460	240	450	2020 kg	55°	4200	5200
T20 C MS	1425/1570	5280	4800	1000	1740	100	3060	2490	240	450	2020 kg	55°	4200	5400
T20 NC MS	1425/1570	5280	5000	1200	1740	100	3060	2520	240	450	2020 kg	55°	4200	5600
T20 N MS	1425/1570	5480	5200	1200	1540	100	3060	2680	240	550	2050 kg	51°	4400	5800
T20 NL MS	1425/1570	5680	5400	1200	1340	100	3060	2820	240	800	2080 kg	48°	4600	6000
T20 L MS	1425/1570	5880	5600	1200	1140	100	3060	2960	240	1000	2110 kg	45°	4800	6200
T20 XL MS	1425/1570	6080	5800	1200	940	100	3060	3100	240	1100	2150 kg	42°	5000	6500

TL20 MS

CONTAINER

MODEL	HG	A	B	C	D	E	F	G	I	L	WEIGHT	α	MIN	MAX
TL20 C MS	1425/1570	6230	5750	1300	1560	130	3280	3130	240	750	2230 kg	54°	4800	6400
TL20 NC MS	1425/1570	6430	5950	1300	1360	130	3280	3260	240	1000	2270 kg	51°	5000	6600
TL20 N MS	1425/1570	6630	6150	1300	1160	130	3280	3390	240	1100	2310 kg	48°	5200	6800
TL20 NL MS	1425/1570	6830	6350	1300	960	130	3280	3420	240	1300	2350 kg	46°	5400	7000
TL20 L MS	1425/1570	7030	6550	1300	790	130	3280	3650	240	1500	2390 kg	44°	5600	7200