

# IVECO



TECHNICAL DESCRIPTION

**IVECO** *T-way* AT410T43 H

## List of linked VCB

VCB code	Gearbox	Wheelbase	Cabin	Drive
SWFIL5B2	I6S 2220 TO	4500	AT-SX	LH
SWFIL5B4	I6S 2220 TO	4500	AT-SX	LH
SWFIL5D2	I6TX 2240 TO	4500	AT-SX	LH
SWFIL5D4	I6TX 2240 TO	4500	AT-SX	LH
SWFIL6B2	I6S 2220 TO	4750	AT-SX	LH
SWFIL6B4	I6S 2220 TO	4750	AT-SX	LH
SWFIL6D2	I6TX 2240 TO	4750	AT-SX	LH
SWFIL6D4	I6TX 2240 TO	4750	AT-SX	LH
SWFIL7B2	I6S 2220 TO	5020	AT-SX	LH
SWFIL7B4	I6S 2220 TO	5020	AT-SX	LH
SWFIL7D2	I6TX 2240 TO	5020	AT-SX	LH
SWFIL7D4	I6TX 2240 TO	5020	AT-SX	LH
SWFIL9B2	I6S 2220 TO	5820	AT-SX	LH
SWFIL9B4	I6S 2220 TO	5820	AT-SX	LH
SWFIL9D2	I6TX 2240 TO	5820	AT-SX	LH
SWFIL9D4	I6TX 2240 TO	5820	AT-SX	LH

# Dimensions & Weights

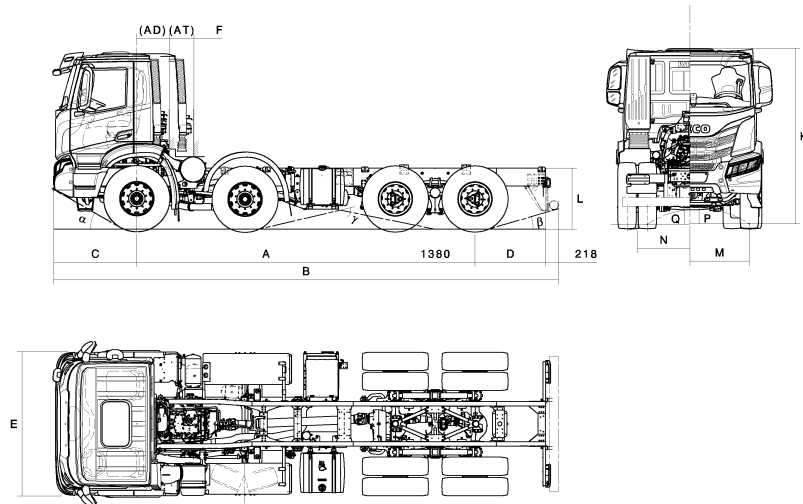

**DIMENSIONS (mm)**

Wheelbase (A)	4500 1380	4750 1380	5020 1380	5820 1380
Max length (B)	8763	9013	9553	10092
Max width over wings (cab) (E)	2550	2550	2550	2550
Front axle to back of cab - including snorkel (F)	990	990	990	990
Frame height at end of frame, unladen (L) (drum brakes)	1145	1144	1143	1144
Frame height at end of frame, unladen (L) (disc brakes)	1146	1145	1143	1145
Frame height at front axle, unladen (drum brakes)	1171	1171	1172	1171
Frame height at front axle, unladen (disc brakes)	1172	1172	1172	1172
Frame height at rear axle, unladen (drum brakes)	1152	1151	1151	1150
Frame height at rear axle, unladen (disc brakes)	1153	1152	1151	1151
Front overhang (C)	1440	1440	1440	1440
Rear overhang (D)	1225	1225	1495	1225
Minimum ground clearance (front) (P)	337	337	337	337
Minimum ground clearance (rear) (Q)	311	311	311	311
Overall height to top of cab, unladen (K) (drum brakes)	3188	3188	3188	3188
Overall height to top of cab, unladen (K) (disc brakes)	3189	3189	3189	3189
Turning diameter kerb to kerb	17800	18500	19200	21300
Turning diameter wall to wall	19400	20100	20800	22900
Front track (M) (drum brakes)	2043	2043	2043	2043
Front track (M) (disc brakes)	2043	2043	2043	2043
Rear track (N) (drum brakes)	1831	1831	1831	1831
Rear track (N) (disc brakes)	1827	1827	1827	1827
Approach angle $\alpha$ (°)	30	30	30	29
Ramp angle $\gamma$ (°)	24	23	22	17
Departure angle $\beta$ (°)	16	16	13	16

# Dimensions & Weights

## DIMENSIONS (mm)

Wheelbase (A)	4500 I380	4750 I380	5020 I380	5820 I380
Side members thickness	10	10	10	10
Side members max height	309	309	309	309
Side members flange width	80	80	80	80
Frame width at rear	776	776	776	776

## WEIGHTS (kg)

Wheelbase (A)	4500 I380	4750 I380	5020 I380	5820 I380
Total vehicle kerb weight (drum brakes)	10543	10665	10730	10790
Total vehicle kerb weight (disc brakes)	10377	10500	10564	10625
Kerbweight on Front Axle (drum brakes)	7106	7111	7081	7097
Kerbweight on Front Axle (disc brakes)	7034	7040	7010	7026
Kerbweight on rear axle (drum brakes)	3437	3554	3649	3693
Kerbweight on rear axle (disc brakes)	3343	3460	3554	3599
G.V.W. (EC)	32000	32000	32000	32000
G.V.W. (Design)	41000	41000	41000	41000
Plated weight on front axle (EC)	16000	16000	16000	16000
Plated weight on front axle (Design)	16000	16000	16000	16000
Plated weight on rear axle (EC)	19000	19000	19000	19000
Plated weight on rear axle(s) (Design)	26000	26000	26000	26000

### Notes :

Weights are to standard configuration and include: chassis cab (or tractor), driver (75 kg), full fuel and Adblue tanks (if present), tools kit and spare wheel (if present).  
The values of the plated weights / GVW can vary according to the markets and local homologations.

Wheelbase	Type	Drawing
4500 I380	Left hand drive vehicle drawing	5803035209
4750 I380	Left hand drive vehicle drawing	5803035210
5020 I380	Left hand drive vehicle drawing	5803035211
5820 I380	Left hand drive vehicle drawing	5803035212

# Model Components

## Engine

Identification Code	F3HGE611
Manufacturer	FPT Industrial
Commercial name	Cursor 13
Cycle	Diesel
Injection type	Bosch CPN5-22/2
4 Stroke / 2 Stroke cycle	4
No. of cylinders	6
Cylinders layout	IN-LINE
Bore mm	135
Stroke mm	150
Total displacement cm <sup>3</sup>	12900
Exhaust gas treatment	syencer
Weight (without oil / water) Kg	1230
Injection system	electronic common rail
Injection governor type	Bosch MDI CE101
Cold starting type	THERMOSTARTER
Cooling system	water



### ENGINE EMISSION EURO III opt. 06044

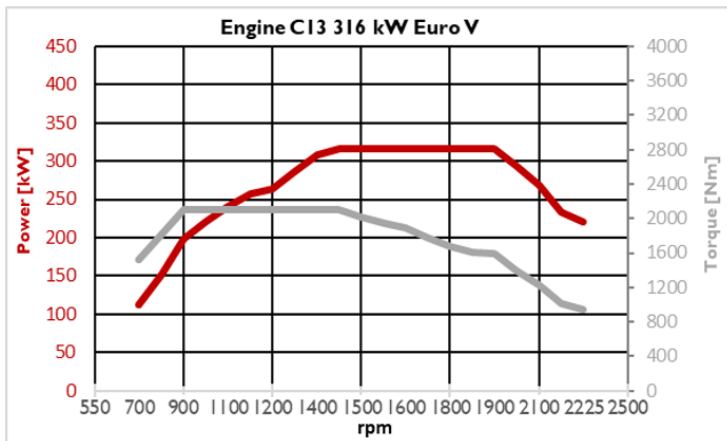

### 430 C13 - Cursor 13 - 430 CV - WG

Maximum power: 316 kW (430 HP) @ 1900 rpm

Maximum torque: 214 Kgm (2100 Nm) @ 1100 rpm

The central electronic system controls the following functions: Engine preheating, fuel preheating, turbo, injection control, engine brake, control of engine speed and torque, data exchange OBD with ScanTool, engine diagnostic (onandoff-board), control of blink-code and failure indicator light on dashboard, control of engine idling speed and max. engine speed, data exchange with VCM (vehiclecontrol module), supervision of emission values.

## DRIVELINE

### Gearbox

Gearbox model	Gearbox Type	Installation	Box material	Dry weight Kg	Clutch type	Max input torque Nm	No. of forward gears	No. of reverse gears	Shifting
16S 2220 TO	SYNCRONIZED	ENGINE FLANGED	ALUMINIUM ALLOY	304.5 - (w/o retarder) 290 - (w/o retarder)	Dry clutch	2200	16	2	HH-Coupling control
16TX 2240 TO	AUTOMATED	ENGINE FLANGED	ALUMINIUM			2200	16	2	

### Gear ratios

Gearbox model	1st	2nd	3rd	4th	5th	6th	7th	8th	9th	10th	11th	12th	13th	14th	15th	16th	rev. 1st	rev. 2nd
16S 2220 TO	13.8	11.54	9.49	7.93	6.53	5.46	4.57	3.82	3.02	2.53	2.08	1.74	1.43	1.2	1.00	.84	12.92	10.8
16TX 2240 TO	14.68	12.05	9.92	8.14	6.78	5.56	4.57	3.75	3.22	2.64	2.17	1.78	1.49	1.22	1.00	0.82	14.14	11.61

# Model Components

## Clutch

Gearbox model	Type	Outer diameter mm	Outer diameter (inches)
16S 2220 TO	Single dry plate	430	17
16TX 2240 TO	Single dry plate	430	17

## Tyres & Wheels

Code	Tyres	Front	Rear	Load index	Rolling circumference m
20081	Standard	13R22,5	13R22,5	156/150	3.428
20885	Optional	385/65R22,5	315/80R22,5	164/	3.28
20795	Optional	315/80R22,5	315/80R22,5	156/150	3.28
20013	Optional	325/95R24	325/95R24	162/160	3.747
20079	Optional	13R22,5	13R22,5	156/150	3.428
20497	Optional	12,00R20	12,00R20	154/149	3.42
20022	Optional	325/95R24	325/95R24	162/160	3.863
20790	Optional	315/80R22,5	315/80R22,5	156/150	3.28
20746	Optional	325/95R24	325/95R24	162/160	3.747
20755	Optional	325/95R24	325/95R24	162/160	3.863

## Rear Axle Ratio

Option code	05003	06017 *	06019	06021	06032	06034	06036
Ratio	6.09	4.231	4.67	5.01	3.79	5.56	6.57

\*: Standard axle ratio

## Performance

\* Max Speed. Calculated speed on the basis of engine rpm and axle ratios. Real speed limits must take into account the speed index of the tyres: K = 110 km / h L = 120 km / h M = 130 km / h

\*\* Theoretically calculated values, arising from the engine torque without considering the road-friction values and the stability limits of the vehicles. When calculating with more than one tyres or more than one axle ratio, availability of each combination must be checked.

\*\*\* Please note that the actual max. speed of the vehicle may differ from the theoretical one displayed in this document, depending on the vehicle configuration.

Speed and gradeability values are rounded.

A = Total Weights (solo vehicle) Kg - Max Gradeability %

B = Total Weights (vehicle+trailer) Kg - Max Gradeability %

Tyre: 20081 - 13R22.5 - Regional / Works

Efficiency: 0.91

No transfer box

### Gearbox model 16S 2220 TO

Axle Ratio	Gear Ratio 1°	Gear Ratio 16°	Speed km/h 1°	Speed km/h 16°	RPM at 80 km/h	RPM at 90 km/h	A		B	
							32000		40000	
							1°	16°	1°	16°
3.79	13.8	0.84	7.47	122.75	1237	1392	70.56	2.49	51.79	1.86
4.231	13.8	0.84	6.69	109.96	1381	1554	84.26	2.98	59.95	2.25
4.67	13.8	0.84	6.06	99.62	1525	1715	100.00	3.45	69.05	2.63
5.01	13.8	0.84	5.65	92.86	1636	1840	100.00	3.80	76.99	2.91
5.56	13.8	0.84	5.09	83.67	1815	2042	100.00	4.36	92.18	3.36
6.09	13.8	0.84	4.65	76.39	1988	2237	100.00	4.89	100.00	3.78
6.57	13.8	0.84	4.31	70.81	2145	2413	100.00	5.37	100.00	4.16

### Gearbox model 16TX 2240 TO

Axle Ratio	Gear Ratio 1°	Gear Ratio 16°	Speed km/h 1°	Speed km/h 16°	RPM at 80 km/h	RPM at 90 km/h	A		B	
							32000		40000	
							1°	16°	1°	16°
3.79	14.68	0.82	7.02	125.75	1208	1359	77.73	2.38	56.16	1.77
4.231	14.68	0.82	6.29	112.64	1348	1517	94.25	2.87	65.41	2.16
4.67	14.68	0.82	5.70	102.05	1488	1674	100.00	3.33	75.96	2.53
5.01	14.68	0.82	5.31	95.12	1597	1796	100.00	3.68	85.40	2.81
5.56	14.68	0.82	4.79	85.72	1772	1993	100.00	4.23	100.00	3.25

# Model Components

Axle Ratio	Gear Ratio 1°	Gear Ratio 16°	Speed km/h 1°	Speed km/h 16°	RPM at 80 km/h	RPM at 90 km/h	A		B	
							32000		40000	
							1°	16°	1°	16°
6.09	14.68	0.82	4.37	78.26	1941	2183	100.00	4.75	100.00	3.67
6.57	14.68	0.82	4.05	72.54	2094	2356	100.00	5.21	100.00	4.04

## FRONT BUMPER

Steel front bumper

## Disc brakes

**DUO DUPLEX drum brakes**  
Electronic braking system (EBS)

**Front axle**  
Drum brakes 410 mm (410 x 180)  
Friction area: 2884 cm<sup>2</sup>

**Tandem**  
Drum brakes 410 mm (410 x 200)  
Friction area: 3220 cm<sup>2</sup>

or

**Disc brakes allround**  
Electronic braking system (EBS)  
Brake Assist System (BAS)

ESP with OFF ROAD MODE available as option

## Axles

Position	Description
Front	5890/D OFF - Axle drop: 72 mm
Front	5890/T OFF - Assale con Drop di 72 mm
Rear	453291/2D - Tandem H.R. (Drum brake 2D)
Rear	453291_ADB - Tandem Hub Reduction (Disc Brakes)

## Suspensions

Front parabolic suspension:  
Standard capacity: 8.000 kg (options for 8.500 kg and 9.000 kg)

Rear parabolic suspension STD (semi-elliptic option):  
Standard capacity: 26.000 kg

# Model Components

## Battery

Electrics	
Voltage V	24
Alternator power V/A	24 / 90
Starter power kW	5.5
No. of batteries	2
Batteries capacity V/Ah	12 / 170

## FUEL TANK 290 L

Fuelling	
Capacity (l.)	290
Material	Aluminium

## 390L FUEL TANK

Fuelling	
Capacity (l.)	390
Material	Aluminium

## Miscellaneous

### THE AVAILABILITY OF THE FOLLOWING OPTIONS DEPENDS ON VERSIONS AND MARKETS :

#### SAFETY :

**TPMS (on cluster): Tyre Pressure Monitoring System** is an electronic system which monitors the air pressure inside a tyre and provides information on faults in real time to the driver. In addition to improving vehicle safety, **TPMS** helps the driver plan tyre maintenance and contributes to reducing fuel consumption.

**ESP: Electronic Stability Program (ESP).** The **ESP** system acts in skidding phase, by adjusting the engine power and braking on individual wheels with different intensities so as to stabilise the position of the vehicle. It is effective both in case of sudden deviations from the trajectory and in correcting situations of oversteer or understeer, which may occur in case of incorrectly approaching a bend.

**LDWS: Lane Departure Warning System (LDWS).** The Lane Departure Warning System beeps when the vehicle strays from the lines that mark the driving lane without the indicators being activated. The system is very effective in preventing accidents due to distraction or sleepiness.

#### FUEL CONSUMPTION OPTIMIZATION:

**ECOSWITCH:** Designed to reduce fuel consumption, **ECOSWITCH** is an important aid for the driver. It activates the "Eco program" in order to optimise gear shifting strategy and performance according to actual vehicle weight, assuring the best productivity under any operating condition.

**ECO ROLL:** On all type of incline (also on moderate one), the eco-roll function serves to open the driveline and retain the kinetic energy of the vehicle for longer or to slightly increase it by reducing the engine-drag torque that affects the impellers. If the vehicle subsequently slows down, the engine must increase the injected fuel quantity at a later point. Driver actions during an active rolling function such as accelerator pedal, brake actuation, changing to manual, or speed range selector actuation lead to the termination of the rolling function and the closing of the driveline. Depending upon the speed range, the last gear before the rolling phase can be engaged or a new gear can be calculated and engaged when the rolling function is terminated.

**ECO ROLL** works in the range (50km/h ; 92km/h) and is independent from Cruise Control setting.

**GPS-PREDICTIVE DRIVING** (OPT Code 78878) GPS-predictive driving is the driving strategy implemented in TraXon with predictive functionality to determine the optimal gear early for any driving situation, according to the electronic horizon information acquired via GPS by a provider and made available on the CAN bus. The electronic horizon acquires the current location of the vehicle via GPS and determines the route from topographical street maps (uphill gradient, curves, max permissible speed). GPS-predictive driving is used to improve the gear shifting and Eco-rolling strategy.

#### DRIVEABILITY :

**ROCKING MODE** (OPT Code 78507) TRAXON provides a Rocking function to have the clutch reating directly to accelerator pedal movements for rocking the vehicle out of a depression in the terrain in low grip conditions. When the Rocking mode is activated, it is possible to disengage the clutch immediately by releasing the accelerator pedal, roll back the vehicle and engage the clutch immediately again by depressing the accelerator pedal. The HMI provided for the Rocking mode includes: a dedicated switch to let the driver activate / deactivate the Rocking mode. A specific indication on the Instrument Cluster to inform when the Rocking function is active ("ROCK" indication in the transmission modes area).

**OFF-ROAD MODE** is an high mobility function with which the gearshifting logic allows higher rpms before shifting to faster gears, thus providing higher engine power and torque.

**CREEPING MODE** is an high mobility function with which the vehicle moves forward at minimum speed, simply by releasing the service brake pedal, useful for precise maneuvering operations at low speed (active via Quick Menu).

# IVECO